



## Spare Parts Catalogue

Dishwashers \ ASKO 5000 XXL Series  
Type: DW70.3  
Model: D5233 XXL US SS

Prod. No: 1075233121  
October 29th 2009

**ASKO Appliances Inc.**

4001 E Plano Parkway #1004001 E Plano Parkway #100  
Plano, Texas 75074

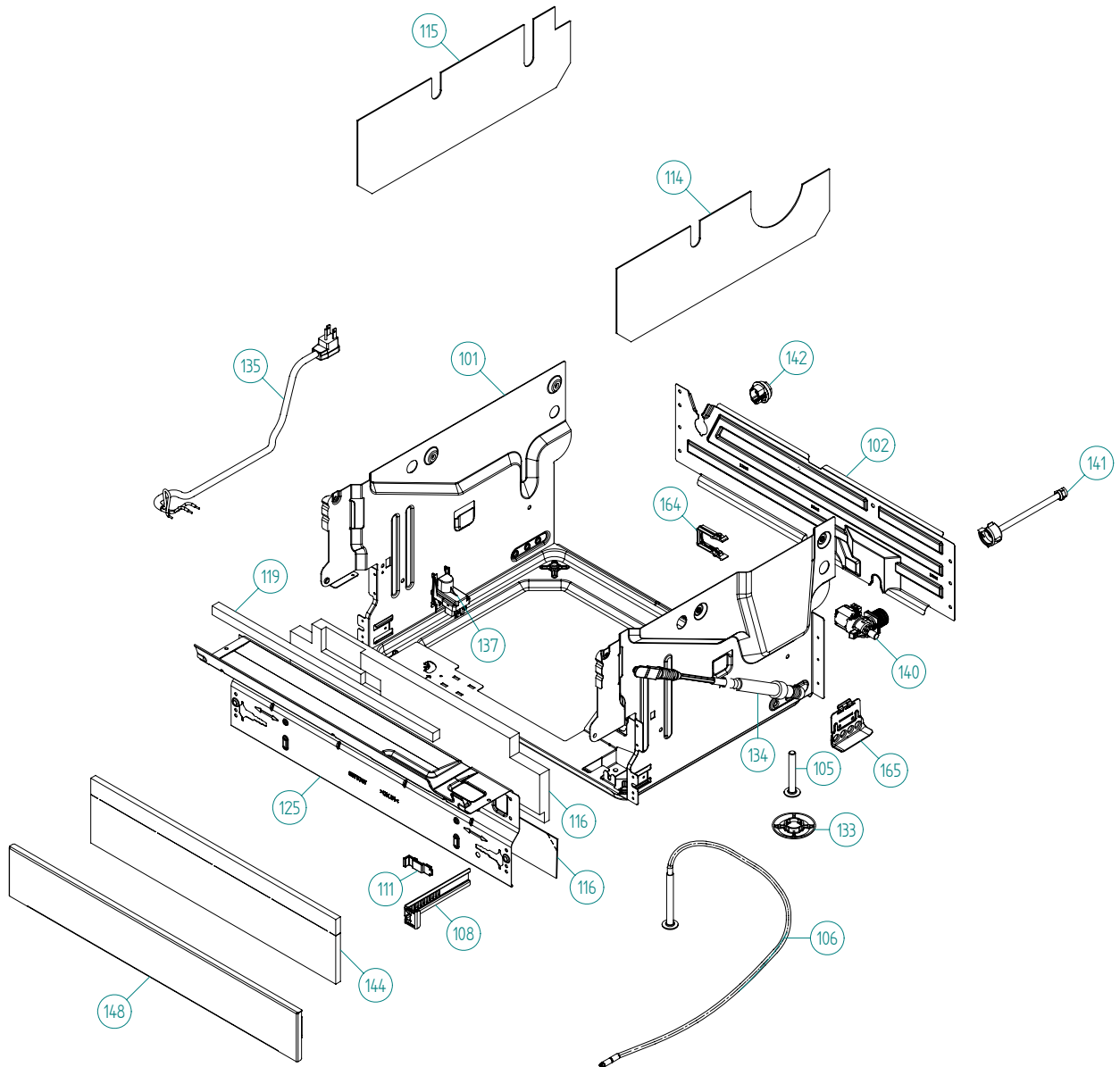

## Base & Related Parts

ASKO, D5233 XXL US - SS #1075233121 (DW70.3)

Pos	Spare part No.	Description	Qty	Comment
101	8801387	BOTTOM OUTER COMPL.	1 Pc's	
102	8078006	REAR PANEL	1 Pc's	
105	8074228	Foot	2 Pc's	
106	8082222	FOOT ADJUSTABLE FROM FRONT CPL	1 Pc's	
108	8073480	Toe Kick bracket Right & Left	2 Pc's	
111	8073481-49	Spring Kicking Plate L Gray	2 Pc's	
114	8078109	SOUND ABSORP. SELF AD. RIGHT	1 Pc's	
115	8078108	SOUND ABSORP. SELF AD. LEFT	1 Pc's	
116	8078114	SOUND ABSORBENT GUARD PLATE	1 Pc's	
119	8078122	SOUND ABSORBTION PROFILE	1 Pc's	
125	8078008	GUARD PLATE STRAIGHT	1 Pc's	
133	8051957	Glide Foot	3 Pc's	
134	8079529	Door Spring-DW70-Red	1 Pc's	
134	8079528	Door Spring-DW70-Yellow	1 Pc's	
135	8083262	CORD SET 15A AMERICA	1 Pc's	
135	8079046	CORD SET AMERICA	1 Pc's	
136-a	8902131	Screw	1 Pc's	
137	8083041	FILTER WITH SCREWPLINT	1 Pc's	
137-a	8901097	Screw Terminal	1 Pc's	
140	8801376	KIT INL.VALVE/LOCKARM SING120V	1 Pc's	
140-a	8079597	LOCK ARM INLET VALVE	1 Pc's	
141	8079522	PEX Inlet hose DW	1 Pc's	
142	8006948	Grommet	1 Pc's	
144	8074585	Felt Kick Plate 05	1 Pc's	
148	8073506-81	kick plate metallic	1 Pc's	
162	8079832	CABLE HOLDER SRC-8-01	1 Pc's	
164	8079597	LOCK ARM INLET VALVE	1 Pc's	
165	8078013	DOOR SPRING HOLDER	1 Pc's	
165-a	8902362	SCREW RTK ST 4,2X9,5 FZB WAX.	1 Pc's	

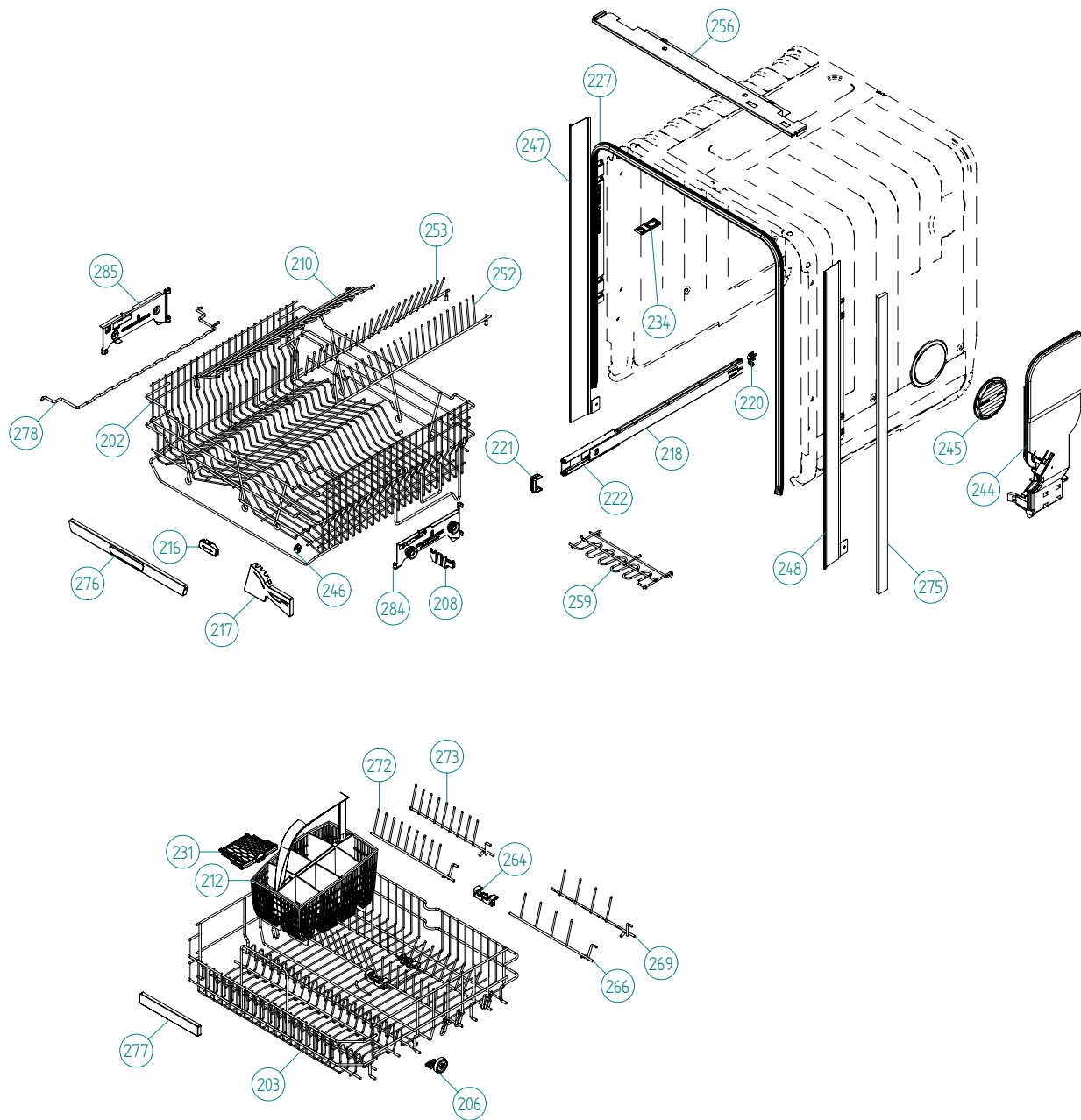

## Baskets & Related Parts

### ASKO, D5233 XXL US - SS #1075233121 (DW70.3)

Pos	Spare part No.	Description	Qty	Comment
201	8057056	-	1 Pc's	Not a spare part
202	8801358-36	UPPER BASKET EXCL. COMPL. H&L	1 Pc's	
203	8801316-36	LOWER BASKET EXCL D.GREY 07	1 Pc's	New design
206	8079257-77	WHEEL FOR LOW DISHW BASKET CPL	8 Pc's	New design
208	8071214-77	Knife Holder 05/06 DW	2 Pc's	
210	8071337-36	Cup Shelf Wine Glass 05/06 DW	1 Pc's	
212	8801317-77	CUTLERY BASKET COMPL. 07	1 Pc's	New design
216	8072553-77	BRACKET PIN ROW UPPER BASKET	1 Pc's	
217	8072554-77	KNIFE GUARD	1 Pc's	
218	8057052	DW Upper Basket Guide Rail	2 Pc's	
220	8057978-77	DW Rail Stop - Back Grey	2 Pc's	
221	8057979-77	Rack Stop Grey 05/06 DW	2 Pc's	
222	8801349-77	KIT BALL HOLDER INCL. BALLS	1 Pc's	
225	8057978-77	DW Rail Stop - Back Grey	2 Pc's	
227	8057489-F	DOOR STRIP XXL DW70	1 Pc's	
231	8079251-77	DOOR CUTLERYBASKET UL4	1 Pc's	New design
234	8070649	Lock Hitch Int	1 Pc's	
234-a	8070648	Lock Washer Int	1 Pc's	Part of 8070469
234-b	8901104	Screw 20 Torx Machine	1 Pc's	
244	8078300	AIRBREAK STD. DW70 UL4	1 Pc's	
245	8057536-77	Lockring Airbreak Gray	1 Pc's	
246	8075350	Clip for Knife Guard	1 Pc's	
247	8074342-E-95	Trim Strip Left XL/XXL	1 Pc's	
247-a	8900646	Screw 20 Torx SS	2 Pc's	
248	8074343-E-95	Trim Strip Right XL/XXL	1 Pc's	
248-a	8900646	Screw 20 Torx SS	2 Pc's	
252	8072552-36	PLATERACK RIGHT U-BASKET	1 Pc's	
253	8072551-36	PLATERACK LEFT U-BASKET	1 Pc's	
256	8075663-95	Trim Rail XL/XXL	1 Pc's	
259	8076619-36	wine glass cup shelf divider	2 Pc's	
264	8076632-77	Holder	3 Pc's	
266	8079130-36	PLATERACK SHORT&THIN LEFT	1 Pc's	
269	8079131-36	PLATERACK SHORT&THIN RIGHT	1 Pc's	
272	8079123-36	PLATERACK SHORT LEFT D-GREY	1 Pc's	
273	8079124-36	PLATERACK SHORT RIGHT D-GREY	1 Pc's	
275	8070614	SEALING STRIPE TRIM STRIPE USA	2 Pc's	
276	8801330-77	HANDLE U-BASKET COMPL. ASKO	1 Pc's	
277	8801332-77	HANDLE LOWER BASKET COMPL.	1 Pc's	
278	8072764-36	GLASS SUPPORT D-GREY	1 Pc's	
278	8079144-36	GLASS SUPPORT D-GREY	1 Pc's	
284	8079138	Basket Adj Bracket Right	1 Pc's	
285	8079139	Basket Adj Bracket Left	1 Pc's	
287	8083397	LOCKINK PLUG F ADJUST. DEVICE	2 Pc's	

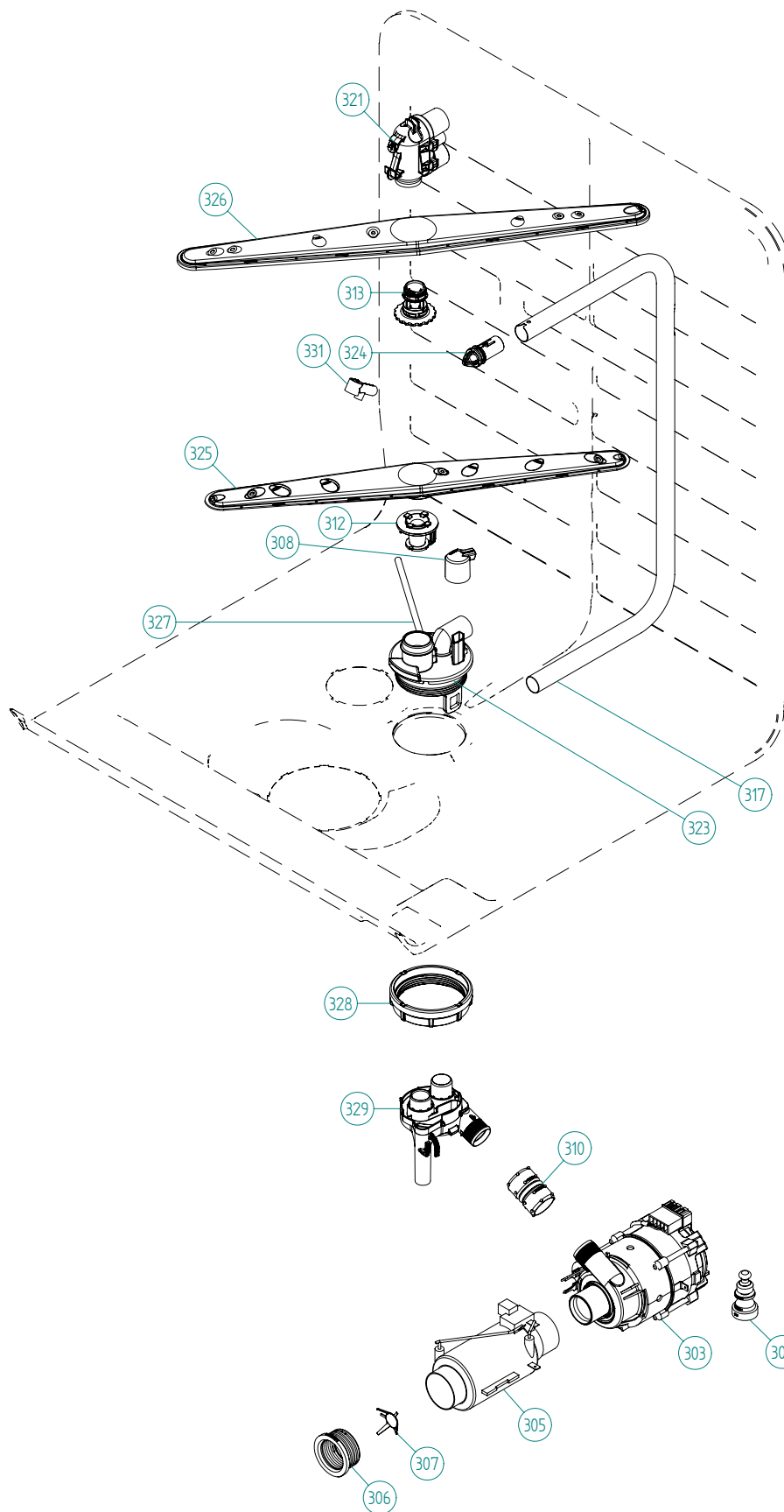

## Wash System

ASKO, D5233 XXL US - SS #1075233121 (DW70.3)

Pos	Spare part No.	Description	Qty	Comment
301	8078001	-	1 Pc's	Not to be ordered
303	8078082	CIRC.PUMP 120V 60HZ	1 Pc's	
303-a	8083804	Capacitor 7,0UF 400V P2 CLASS	1 Pc's	
304	8075130	Rubber Damper Circ Pump	1 Pc's	
305	8079505	HEATING ELEMENT 1200W DW70	1 Pc's	
306	8079531	SEALING HEATER DW70 UL4	2 Pc's	
307	8079575	INSERT FOR HEATER	1 Pc's	
308	8073385-77	Cup Drainage Gray	1 Pc's	
310	8072888	Hose Circ Pump	1 Pc's	
310-a	8056491	HOSE CLIP 30.1-708	2 Pc's	
312	8076901-77	Spray arm bearing	1 Pc's	
313	8079108-77	SPRAYARM BEARING H&L U.BASKET	1 Pc's	
317	8079112-E	SPRAY PIPE H&L UPPER BASK. XXL	1 Pc's	
321	8801359	SPRAYTOWER COMPL H&L BASKET	1 Pc's	
323	8801270	KIT SPRAYARM BEAR. LOW NOZZLE	1 Pc's	
323-a	8901765	ORing det Comp 03/04 DW	1 Pc's	
324	8079113-77	GUIDE SPRAYTUBE ADJ BASKET	1 Pc's	
325	8072891	Spray Arm Lower Complete	1 Pc's	
326	8079111	SPRAYARM CPL H&L BASKET	1 Pc's	
327	8073381	Tube Pot Rinse	1 Pc's	
327-a	8902085	Screw 20T for Plastic	2 Pc's	
328	8071607	Locking Spray Pipe Bearing	1 Pc's	
329	8078086	INTERMEDIATE	1 Pc's	
331	8072543-77	Spray Nozzle	1 Pc's	For part no 8073381 and 8072730-L-77

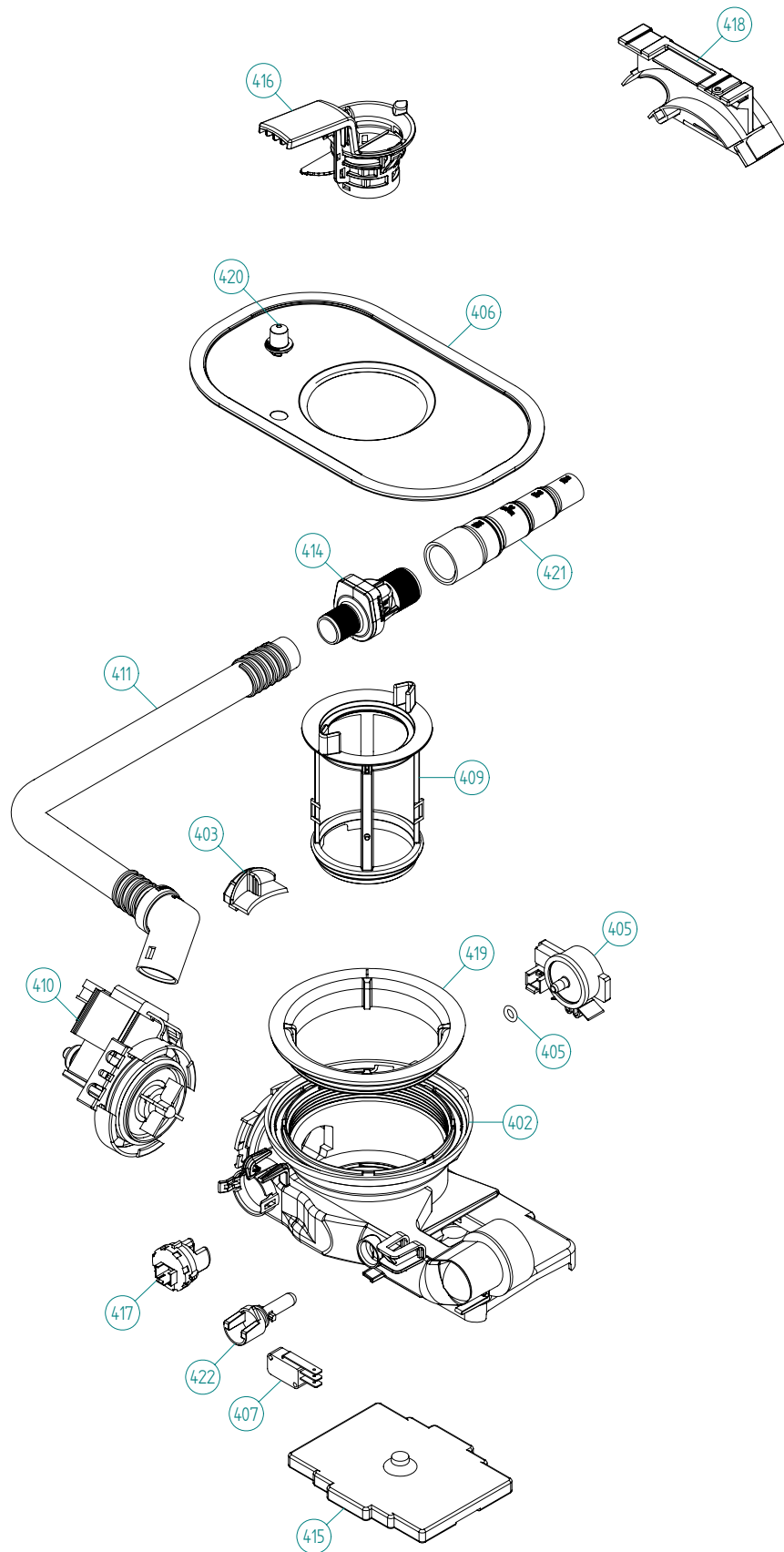



## Bottom Well & Related Parts

ASKO, D5233 XXL US - SS #1075233121 (DW70.3)

Pos	Spare part No.	Description	Qty	Comment
402	8801404	KIT BOTTOM WELL 2 SENSOR DW70	1 Pc's	
402	8078032	BOTTOM WELL 2 SENSOR UL4	1 Pc's	
402-a	8073002	ORing	1 Pc's	
403	8078033	Rinse Cap Bottom Well - Yellow	1 Pc's	
405	8073839	Pressure Sensor	1 Pc's	
405-a	8074040	O-Ring	1 Pc's	
406	8074364	Strainer DW20	1 Pc's	
407	8073835	Microswitch Float	1 Pc's	
409	8078038-77	Pipe Filter DW70	1 Pc's	
410	8078089	Drain Pump 120V 60Hz	1 Pc's	
411	8079693	Outlet Hose w/o Return Valve	1 Pc's	
414	8801248	Check Valve Kit	1 Pc's	
414-a	8052239	Hose Clamp	1 Pc's	
414-b	8053642	Hose Clamp	1 Pc's	
415	8078025	Float	1 Pc's	
416	8078039-77	Strainer Basket Grey	1 Pc's	
417	8081321	TURBIDITY SENSOR DW20/70	1 Pc's	
418	8072528-77	Holder Outlet Hose	1 Pc's	
418-a	8053642	Hose Clamp	1 Pc's	
418-b	8052239	Hose Clamp	1 Pc's	
418-c	33700450	Cable Strip	1 Pc's	
418-d	8902072	Screw	1 Pc's	
419	8072848	Lockring Bottom Well	1 Pc's	
420	8074760-77	Ventilator	1 Pc's	
421	8075321	End Cuff	1 Pc's	
422	8078096	Thermistor	1 Pc's	
426	8078024	SEALING NON RETURN VALVE	1 Pc's	

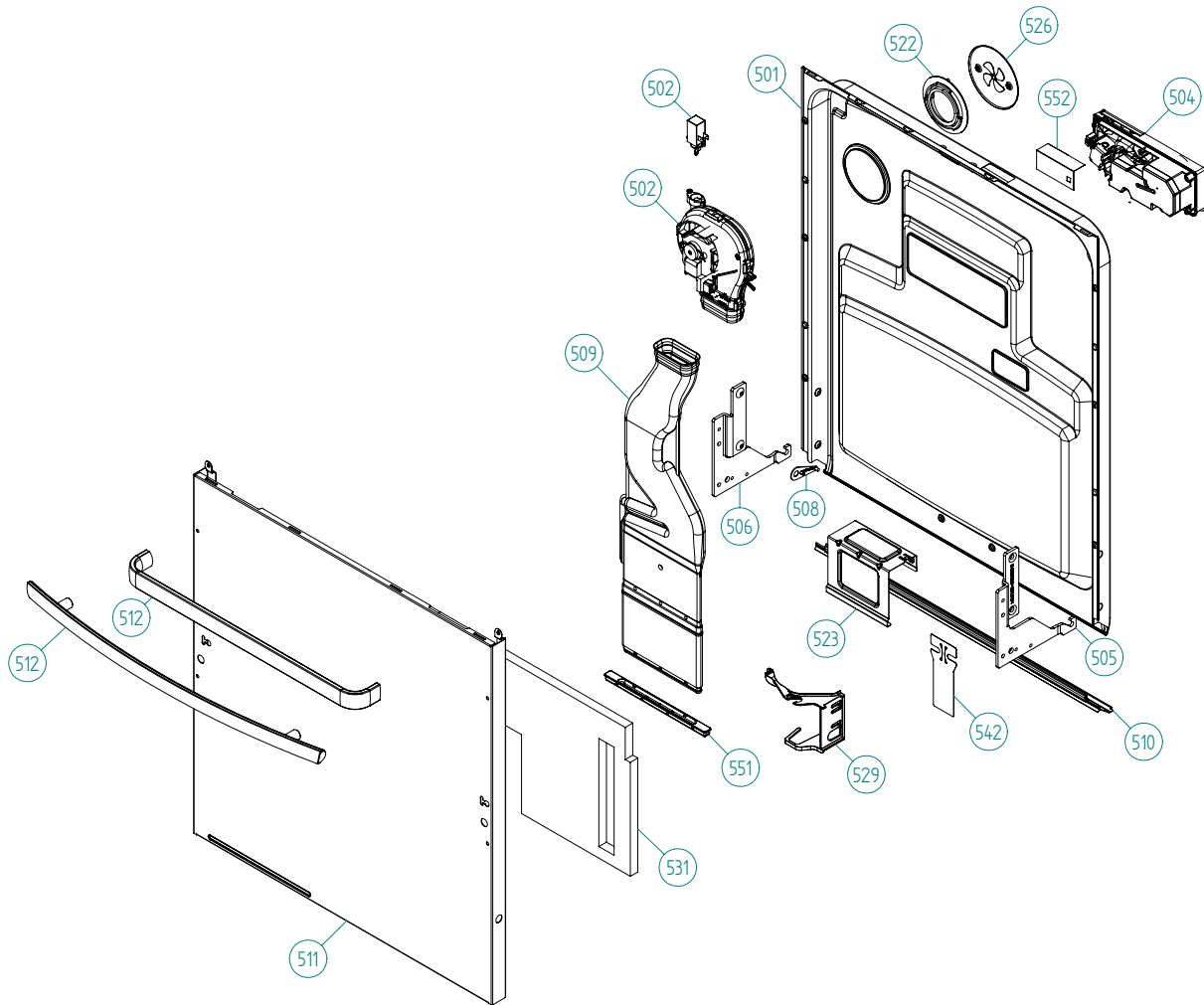

## Inner door, panel and related parts

ASKO, D5233 XXL US - SS #1075233121 (DW70.3)

Pos	Spare part No.	Description	Qty	Comment
501	8801380	Door Inner w/Fan XXL DW70	1 Pc's	
501-a	8900646	Screw 20 Torx SS	6 Pc's	
501-b	8902121	Screw	4 Pc's	
502	8073851	Fan Complete 120V	1 Pc's	
502-a	8058501	ORing Turbo Fan Dry 05/06 DW	1 Pc's	
502-b	8052778	WAX MOTOR DW 05/06	1 Pc's	
504	8801343-77	KIT Combi Dispenser 120V	1 Pc's	
504-a	8071916	SEAL,DET.COMP.LID repl by 8071918	1 Pc's	
504-b	8071917	CAP RINSE AGENT	1 Pc's	
504-c	8071918	Detergent Lid Complete	1 Pc's	
504-d	8072288	Sealing Strip Combi Disp.	1 Pc's	
504-f	8902087	Screw Plastic Housing 20 Torx	6 Pc's	
505	8078004	Hinge Right DW70	1 Pc's	
506	8078005	Hinge Left DW70	1 Pc's	
507	8057530	Screw hinge 05	2 Pc's	
507-a	33500262	Nut Term Block	2 Pc's	
508	8057948	Slide washer hinge bearing 05	2 Pc's	
509	8078040	Air Channel DW70	1 Pc's	
510	8060254	Lower SealInner Door 05/06 DW	1 Pc's	
511	8078019-K-90	Outer Door for Tbar Hndl	1 Pc's	
511-a	8900646	Screw 20 Torx SS	6 Pc's	
512	8073488-95	Handle SS D3232XL	1 Pc's	
512-a	8901969	Screw	2 Pc's	
522	8057964	Locking ring turbo fan 05	1 Pc's	
522-a	8902085	Screw 20T for Plastic	2 Pc's	
523	8057983	Brace	1 Pc's	
523-a	8900646	Screw 20 Torx SS	2 Pc's	
523-b	8902357	Screw	2 Pc's	
526	8058484	SS Coverplate Turbo Fan DW	1 Pc's	
526-a	8902085	Screw 20T for Plastic	2 Pc's	
529	8074278	Bracket for harness	1 Pc's	
531	8074258	Sound Absorbtion Outer Door	1 Pc's	
542	8076966	COVER, CABLES	1 Pc's	
551	8079584-33	Air Channel Nozzle DW70	1 Pc's	
552	8083021	COVER COMBI DISPENSER	1 Pc's	

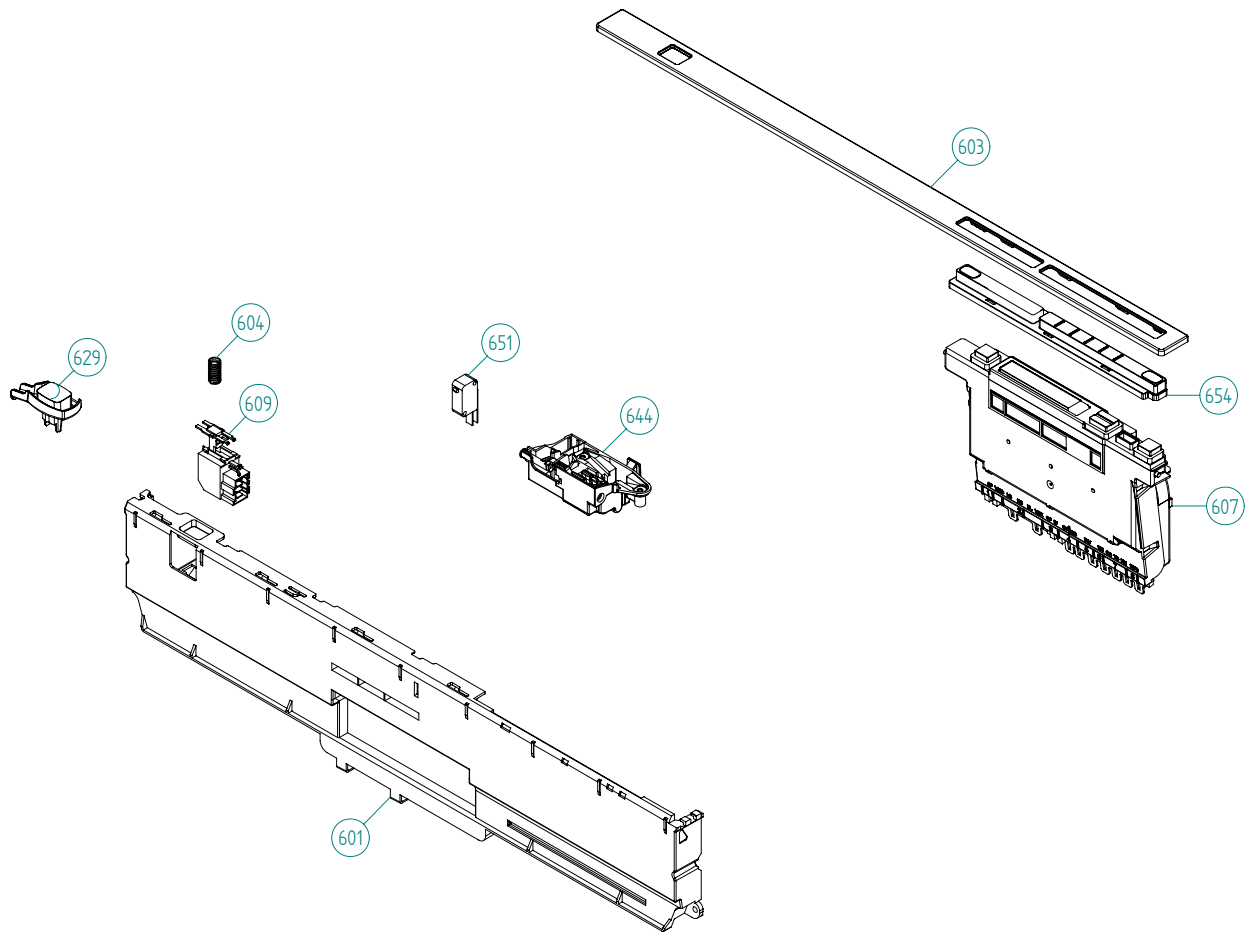

## Control Panel & Related parts

ASKO, D5233 XXL US - SS #1075233121 (DW70.3)

Pos	Spare part No.	Description	Qty	Comment
601	8079543-UL	Control Panel DW70	1 Pc's	
602	8082884	PROG.INFO.LABEL 3KN AUT/DEL US	1 Pc's	
603	8082879-81	CONTROL LENS ASKO D5233 (70.3)	1 Pc's	
604	8074277	SPRING MAIN SWITCH	1 Pc's	
607	8801365	Control Unit DW70.3	1 Pc's	
609	8073782	MAIN PUSH SWITCH	1 Pc's	
610	8079517	CABLE SET THERMIST DW70.3.4.5	1 Pc's	
614	8078068	CABLE SET CIRC.PUMP INL.VALVE	1 Pc's	
616	8078064	CABLE SET FLOW PRESSURE TURB.	1 Pc's	
618	8078070	CABLE SET POWER	1 Pc's	
620	8075730	cable set fan	1 Pc's	
622	8078063	CABLE SET DRAIN	1 Pc's	
629	8081633-81	PUSHBUTTON MAINSW. DW70.3 GRAP	1 Pc's	
644	8073670	Lock Complete Integrated	1 Pc's	
651	8073836	MICROSWITCH DOOR	0 Pc's	
654	8082880-81	PUSH BUTTONS ASKO 70.3 3KN GR.	1 Pc's	
690	8083179	INSTRUCTIONS D5233 USA XXL ENG	1 Pc's	
690	8083180	INSTRUCTIONS D5233 USA XXL FR	1 Pc's	

- CD: COMBI DISPENSER
  - CP: CIRCULATION PUMP
  - DIV: WATER DIVERTER VALVE
  - DP: DRAIN PUMP
  - DR: DOOR
  - DS: DOOR SWITCH
  - F: FILTER
  - FM: FLOW METER
  - FN 1: FAN DOOR
  - FN 2: FAN BOTTOM
  - FS: FLOAT SWITCH
  - HE: HEATING ELEMENT
  - HE (PTC): HEATING ELEMENT PTC
  - HL: HALOGEN LAMP
  - HS: HUMIDITY SENSOR
  - IS: ILLUM. SWITCH
  - IV: INLET VALVE
  - I2C: I2C
  - MS: MAIN SWITCH
  - MV: MIX VALVE
  - PS: PRESSURE SENSOR
  - RAS: RINSE AID SENSOR
  - SL: STATUS LIGHT
  - SS: SALT SENSOR
  - SV: SALT VALVE
  - TH: THERMISTOR
  - TS: TURBIDITY SENSOR
  - UART: UART
  - VAX: VAX ACTUATOR
- WIRES IN ALL MACHINES  
 - - - INTERNAL CONNECTION  
 - · - WIRES IN SOME MACHINES

**RESISTANCES AT ROOM TEMPERATURE (CA. 20°C/68°F)**  
**VALUES WITH +/-10% ARE REGARDED AS NORMAL**

COMPONENT	RESISTANCE
RADIO INTERFERENCE SUPPRESSION FILTER	1 MOHM
HEATING ELEMENT 1200W 120V	12 OHM
HEATING ELEMENT 1600W 230V	32 OHM
HEATING ELEMENT 2040W 230V	25 OHM
THERMISTOR	25 KOHM
COMBINED DISPENSER 120V	0.3 KOHM
COMBINED DISPENSER 230V	1,6 KOHM
CIRCULATION PUMP 120V 60HZ	32 OHM
CIRCULATION PUMP 230V 50HZ	110 OHM
CIRCULATION PUMP 220V 60HZ	56 OHM
DRAIN PUMP 120V 60HZ	25 OHM
DRAIN PUMP 230V 50HZ	150 OHM
DRAIN PUMP 230V 60HZ	85 OHM
SPRAY ARM DIVIDER 120V 60HZ	2.6 KOHM
SPRAY ARM DIVIDER 230V 50/60HZ	8,5 KOHM
INLET VALVE SINGLE INCL. 120V	0.95 KOHM
INLET VALVE SAFETY INCL. 120V	0.5 KOHM
INLET VALVE SINGLE INCL. 230V	3,9 KOHM
INLET VALVE SAFETY INCL. 230V	2 KOHM
SALT VALVE 120V	0,65 KOHM
MIX VALVE 120V	0,65 KOHM
SALT VALVE 230V	3 KOHM
MIX VALVE 230V	2,3 KOHM
HALOGEN LAMP 5W 12V	<10 KOHM
WAX MOTOR	1.1 KOHM
FAN MOTOR 120V	0.18 KOHM
FAN MOTOR 230V	0,85 KOHM

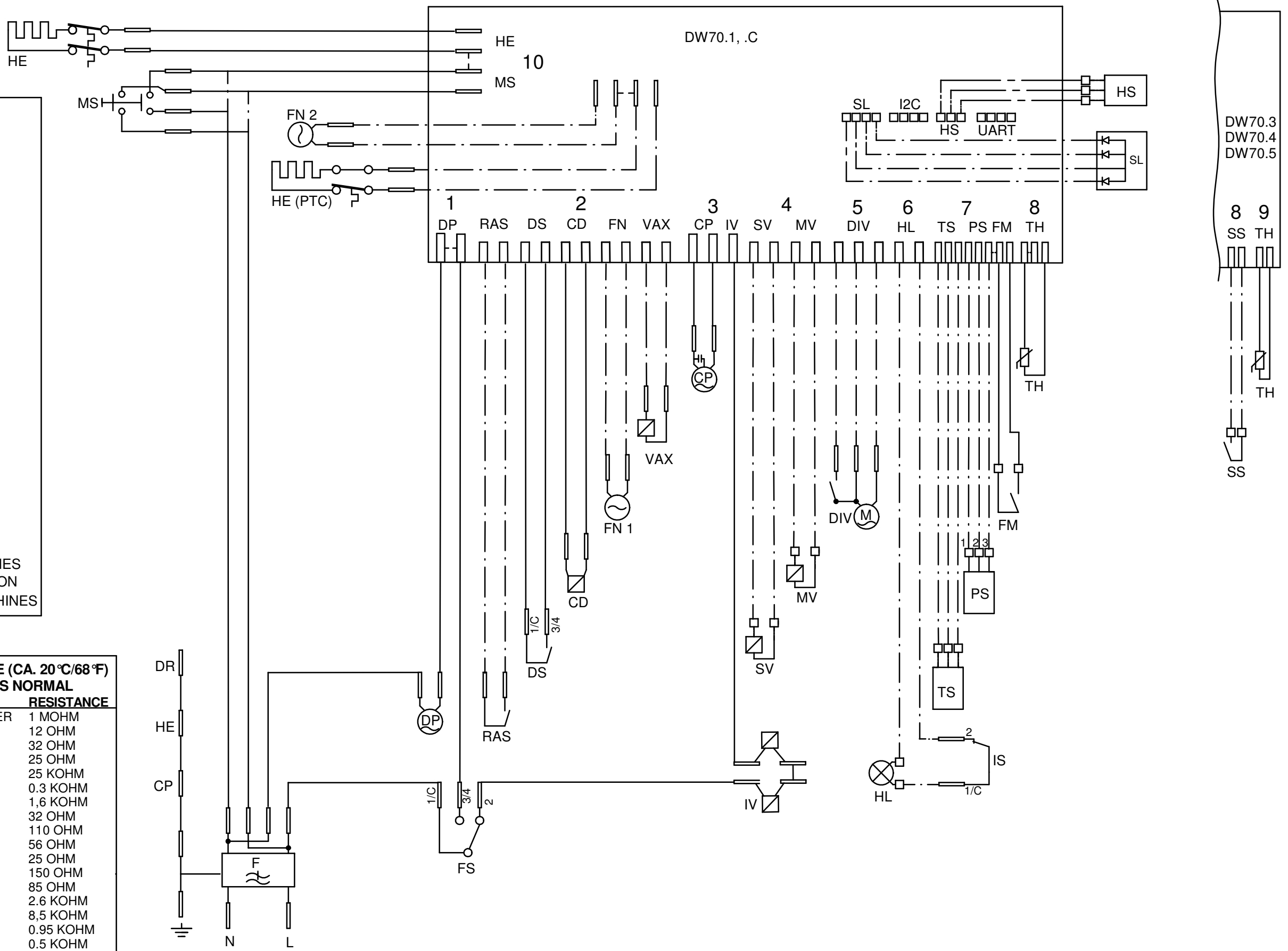

CIRCUIT DIAGRAM DW70.1, .3, .4, .5, .C  
**80 796 55 - 01**

This document must not be copied without our written permission, and the contents thereof must not be imparted to a third party nor be used for any unauthorized purpose. Contravention will be prosecuted. Asko Appliances AB

## Displays

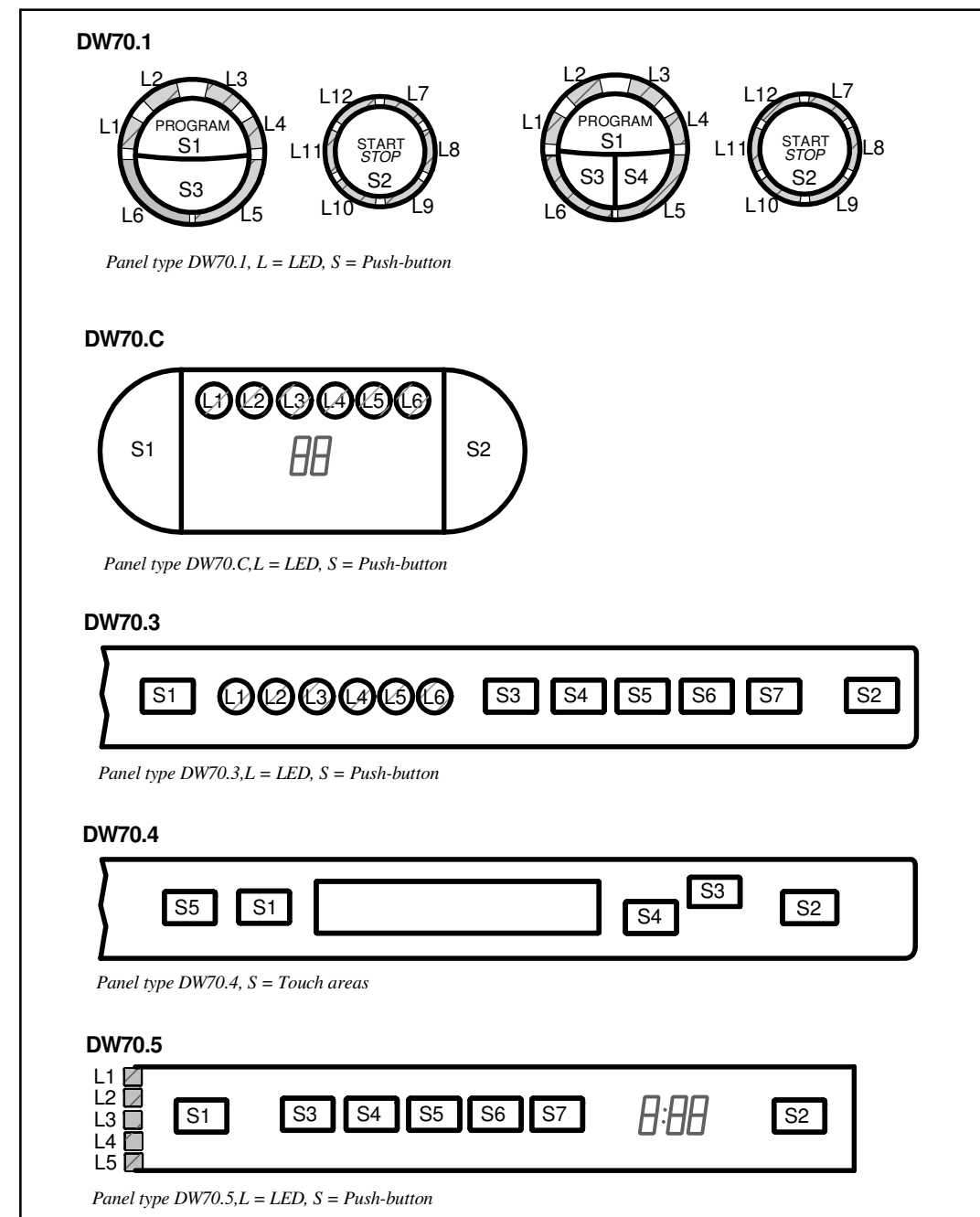

### TOTAL RESET

TURN OFF MAIN SWITCH  
 WAIT FOR AT LEAST 5 SECS  
 HOLD PROGRAM BUTTON (S1), FOR DW70.4 HOLD PROGRAM BUTTON (S1)  
 AND NAVIGATION BUTTON (S4).  
 TURN ON MAIN SWITCH  
 RELEASE PROGRAM BUTTON (S1), FOR DW70.4 RELEASE PROGRAM BUTTON (S1)  
 AND NAVIGATION BUTTON (S4).

### SERVICE MENU

TURN OFF MAIN SWITCH  
 WAIT FOR AT LEAST 5 SECS  
 HOLD PROGRAM AND START BUTTONS (S1 & S2)  
 TURN ON MAIN SWITCH  
 RELEASE PROGRAM AND START BUTTONS (S1 & S2)

### VARIANT SETTING (NOT DW70.4)

HOLD PROGRAM AND START BUTTONS (S1 & S2)  
 TURN ON MAIN SWITCH  
 RELEASE PROGRAM AND START BUTTONS  
 PRESS START (S2) 3 TIMES WITHIN 5 SECS  
 SELECT VARIANT BY START BUTTON (S1) AND  
 CONFIRM BY START BUTTON (S2)

## COMPONENT TEST:

**First enter Service menu.**

### DW70.1, DW70.3, DW70.5 and DW70.C

Component test:

Press the Program button (S1) and index through the following components:

1. Inlet valve and mix valve (only machines with water softener)
2. Inlet valve
3. Salt valve (only machines with water softener)
4. Detergent and surfactant dispenser
5. Circulation pump
6. Heating element and circulation pump (Max 75°C)
7. Fans
8. Drain pump

### DW70.4

**First enter service menu.**

Go to service menu step 2, Diagnostics, by pressing S4

Press (S3) to activate the following components:

1. Valve (Inlet valve and mix valve (only machines with water softener), display flowsensor value)
2. Valve (Inlet valve, display flowsensor value)
3. Salt (Salt valve, only machines with water softener)
4. Disp (Detergent and surfactant dispenser)
5. Circ (Circulation pump, display shows turbidity in Volts)
6. Heat (Heating element and circulation pump (Max 75°C))
7. Fans (display shows humidity sensor value)
8. Drain (Drain pump, display shows pressure sensor reading; 0.5-3.5 VDC)

CIRCUIT DIAGRAM DW70.1, .3, .4, .5, .C

80 796 55 - 01

This document must not be copied without our written permission, and the contents thereof must not be imparted to a third party nor be used for any unauthorized purpose. Contravention will be prosecuted.  
 Askö Appliances AB